

Belgicast®



CHECK VALVES AND STRAINERS

tyco | *Flow Control* | **Tyco Waterworks**

Check Valves and Strainers



Non-return devices in pumping stations, water supply and sewage networks are of great importance in protecting equipment and networks.

In consequence, the criteria for selecting these devices must be based on quality, reliability and durability.

Belgicast offers the widest range of check valves to guarantee the safety of your installations.

Use this catalogue to choose the most suitable valves for your particular requirements, taking water type (clean or waste), working pressure and water hammer performance into account.

This catalogue also includes the **Belgicast** range of strainers for effective network protection.

Manufacturing Programme:



Belgicast BC-03-20 "Y" strainer

Flanged ends
DN 50/300
PN 163



Belgicast BV-05-38

Ball check valve
DN 40/400
PN 10/16/254-5



Belgicast BV-05-91 RUBER-CHECK Model C

Dual plate check valves wafer type
DN 40/1200
PN 10/16/256-7



Belgicast BV-05-91-A RUBER-CHECK Model B

Dual plate check valves wafer type
DN 40/1200
PN 10/250 or ANSI 150/15008-9



Check Valve "Ruber-Check"

EMG/Model from DN 40 to DN 300
PN 6/10/16 JIS 5K/10K
ANSI 15010-11



Belgicast BV-05-92 IPROCHECK

Axial disc check valve flanged ends
DN 50/250
PN 10/1612-13



Belgicast BV-05-37

Swing check valve with flanged ends
DN 50/400
PN 10/1614

Strainers



Belgicast BC-03-20 "Y" STRAINER

FLANGED ENDS
DN - 50/300
PN -16

Characteristics:

- Simple strainer for network protection services.
- Easy maintenance and installation.
- Widely used in irrigation to protect hydrants.

Dimensions and materials:

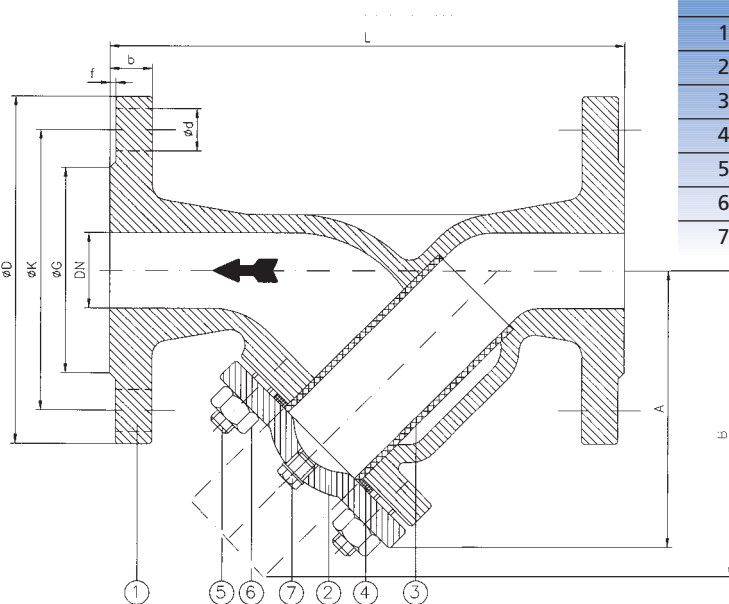

N°	NAME	N° PARTS	MATERIAL
1	BODY	1	GG-25
2	COVER	1	GG-25
3	STRAINER	1	STAINLESS STEEL
4	BODY-BONNET JOINT	1	SINTETIC FIBER
5	THREADED ROD	N/DN	CARBON STEEL
6	BONNET NUT	N/DN	CARBON STEEL
7	DRAINING PLUG	1	FORGED STEEL

DN	L	D	K	G	f	b	d x n°	A	B	Ø STRAINER HOLES	N° OF HOLES PER CM ²	WEIGHT Kg.
50	225	165	125	102	3	20	18x4	150	225	2	7	11,3
65	273	185	145	122	3	20	18x4	200	300	2	7	15,7
80	291	200	160	138	3	22	18x8	222	333	2	7	19,5
100	352	220	180	158	3	22	18x8	241	362	2	7	29
125	416	250	210	188	3	24	18x8	292	438	2	7	40
150	470	285	240	212	3	24	22x8	320	480	2	7	63,4
200	542	340	295	268	3	26	22x12	415	623	2	7	95
250	660	405	355	319	3	28	26x12	482	723	2	7	142
300	762	460	410	370	4	28	26x12	558	837	2	7	202

Ball Check Valves

Belgicast BV-05-38

Ball check valves
DN 40/400 (Flanges)

Belgicast BV-05-38R

DN 1" TO 3" (Gas thread)



Features:

- Ball check valve specially designed for pumping waste water and mud.
- Easy maintenance.
- Anti-corrosion epoxy coating.
- Its low load loss means it can also be used with clean waters.
- Full bore.
- May be fitted horizontally or vertically.
- Temperature from -10°C to +80°C
- Maximum working pressure 10 bar.
- Valid for installation between PN10 or PN16 flanges.

Note:

BV-05-38 and BV-05-38 R valves may also be supplied with balls of lower weight depending on particular requirements.

Similarly, floating balls may be supplied on request for the following models to work as a dual-purpose vent (air admission and discharge):

- BV-05-38: ND-80 to ND-200
- BV-05-38R: ND 40 to ND 65

Operation:

Operation is based on a free ball housed inside the body which is pushed by the pumped flow to the side cavity, allowing the liquid to pass through. When the pump stops and the ball is no longer pushed aside, it takes up a position in the inlet port and prevents flow return.

When installing the check valve at pump outlet, take care to make the installation as far as possible from diffusing cone and elbows. Choose an area of stable flow. It is recommended to install the valve after a straight length of pipe 5 times higher its DN.

Fitting:

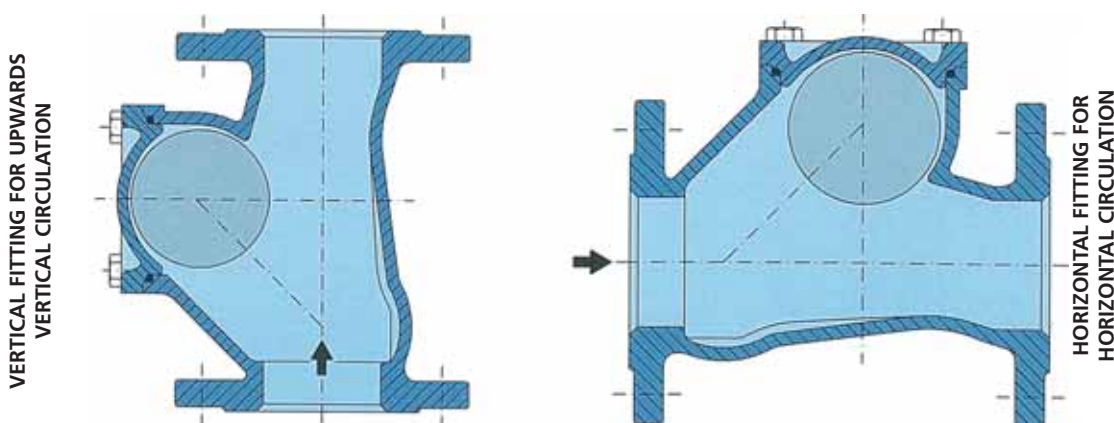

Headlosses:

BV-05-38

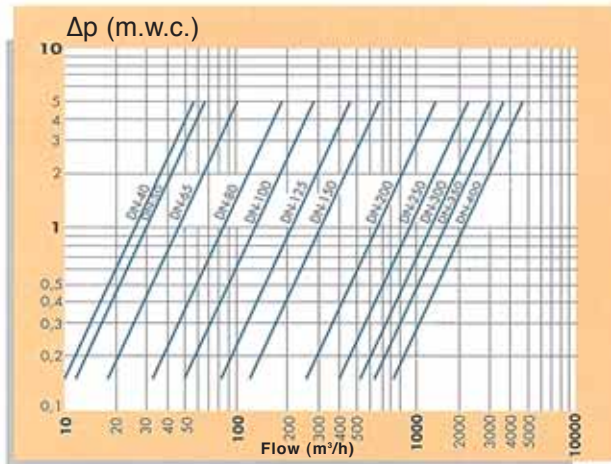

BV-05-38R

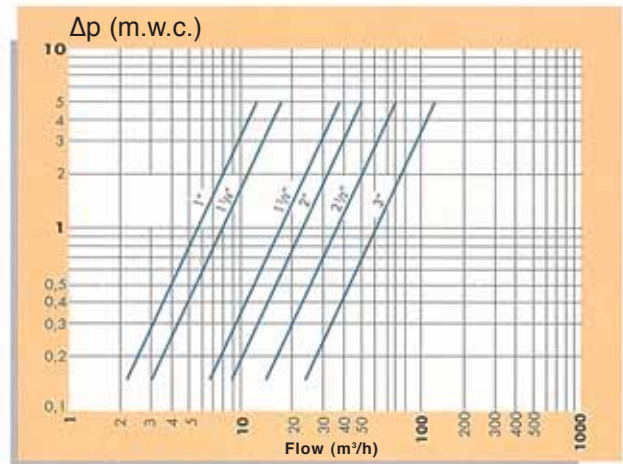

FLANGED ENDS

THREADED ENDS

Materials and dimensions specifications:

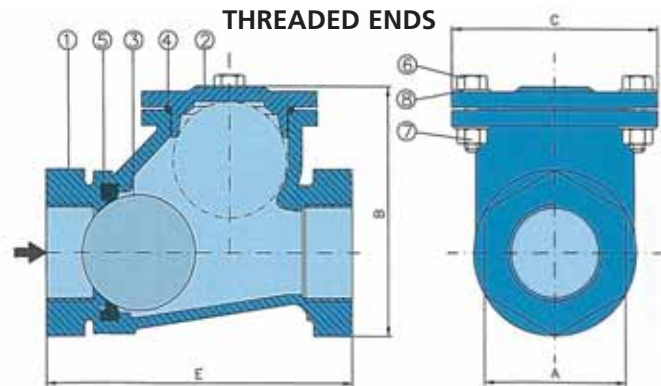
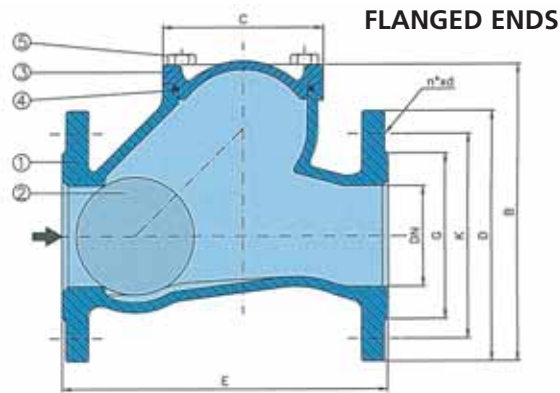

N°	NAME	N° OF PARTS	MATERIAL
1	BODY	1	DUCTILE IRON
2	BALL	1	DN 40/200 ALUMINIUM+NITRYL DN 250/400 GGG-40+NITRYL
3	BONNET	1	DUCTILE IRON
4	BODY BONNET GASKET	1	NITRILE
5	BOLTS	ACC/DN	STAINLESS STEEL

N°	NAME	N° OF PARTS	MATERIAL
1	BODY	1	GGG-40
2	BONNET	1	GGG-40
3	BALL	1	PHENOLIC RESIN
4	BODY BONNET GASKET	1	NITRILE
5	SEAT GASKET	1	NITRILE
6	SCREW	2	STAINLESS STEEL
7	NUT	2	STAINLESS STEEL
8	WASHERS	4	STAINLESS STEEL

DN		ISO 2531 PN-10				E	C	B	KVo m³/h	Weight Kg
mm	"	D	K	G	n°xd					
40	1 1/2	150	110	88	4x19	180	95	172	80	7.5
50	2	165	125	102	4x19	200	95	180	90	8.5
65	2 1/2	185	145	122	4x19	240	114	210	140	12
80	3	200	160	138	8x19	260	128	240	253	15
100	4	220	180	158	8x19	300	160	285	396	22
125	5	250	210	188	8x23	350	200	330	642	34
150	6	285	240	212	8x23	400	230	390	962	45
200	8	340	295	268	8x28	500	320	480	1990	80
250	10	400	350	320	12x28	600	414	600	3100	135
300	12	450	400	370	12x28	700	460	680	4100	200
350	14	505	460	430	16x28	850	596	800	5050	300
400	16	565	515	482	16x28	1100	690	1050	6500	600

DN		A	B	C	E	KVo m³/h	Weight kg.
mm	inch						
25*	1	45	92	96	120	18	1.9
32	1 1/4	50	105	106	135	32	2.4
40	1 1/2	60	115	112	142	58	2.8
50	2	70	155	136	175	75	3.7
65	2 1/2	90	170	155	198	118	6.3
80*	3	105	197	180	238	185	7.6

*Valves without bonnet. Drawing upon request

Dual Plate Check Valve

Belgicast Model C Ruber-Check

Dual plate check valve
Wafer type



DN 40/1200
PN 10/16/25/40

Features:

- Dual plate check valve with soft wafer type seat for fitting between flanges.
- For pumping and services/supplies involving clean or lightly-charged water.
- May be fitted in horizontal or vertical position.
- Anti-corrosion epoxy coating.
- Silent, progressive spring-assisted closing.
- Temperature from -10°C to +80°C.
- Dimensions between faces as per ISO 5752, SERIES 16, DIN 3202 K3

Operation:

- The dual plates open under the pressure exerted by the pumped flow and close immediately after the pump stops, due to the pressure applied by the water column and closing spring.
- When installing the check valve at pump outlet, take care to make the installation as far as possible from diffusing cone and elbows. Choose an area of stable flow. It is recommended to install the valve after a straight length of pipe 5 times higher its DN.

DN		CV	KV m³/sg	mm water column spring action
mm	"			
40	1 1/2	90	0.0215	300
50	2	90	0.0215	300
65	2 1/2	90	0.0215	300
80	3	150	0.0359	300
100	4	300	0.0718	200
125	5	800	0.19157	150
150	6	800	0.19157	150
200	8	1700	0.4070	140
250	10	3000	0.7183	140
300	12	4000	0.9578	130
350	14	5350	1.2811	130
400	16	7400	1.772	100
450	18	10000	2.394	70
500	20	13000	3.113	70
600	24	24000	5.747	60
700	28	40000	9.578	60
800	32	45500	10.895	50
900	36	62000	14.846	50
1000	40	90000	21.551	40
1200	48	130000	31.130	30

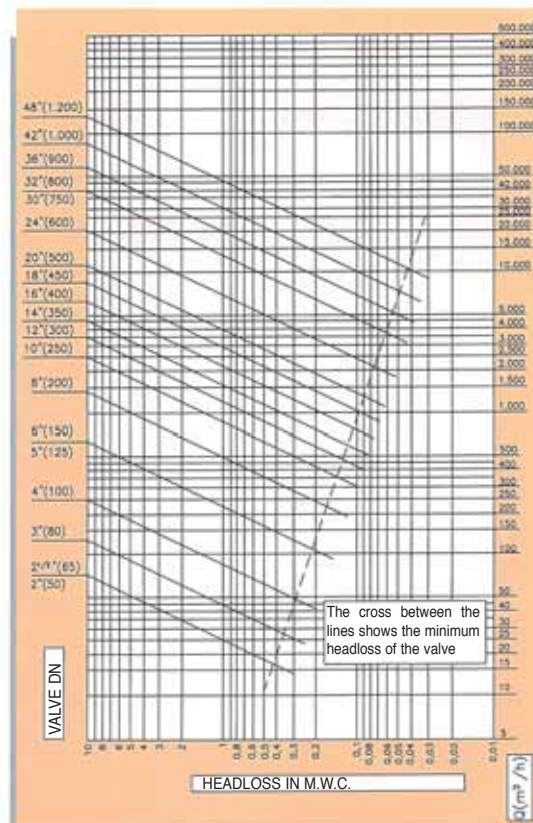

Materials:

- Body and plates: cast iron GG-25 and ductile iron GGG-40, carbon steel, stainless steel.
- Shafts: AISI-304, AISI-316, Monel 400.
- Springs: AISI-302, INCONEL-X, AISI-316.
- Seats: Nitrile, EPDM, viton.
- Other materials upon request.

Dimensions specifications:

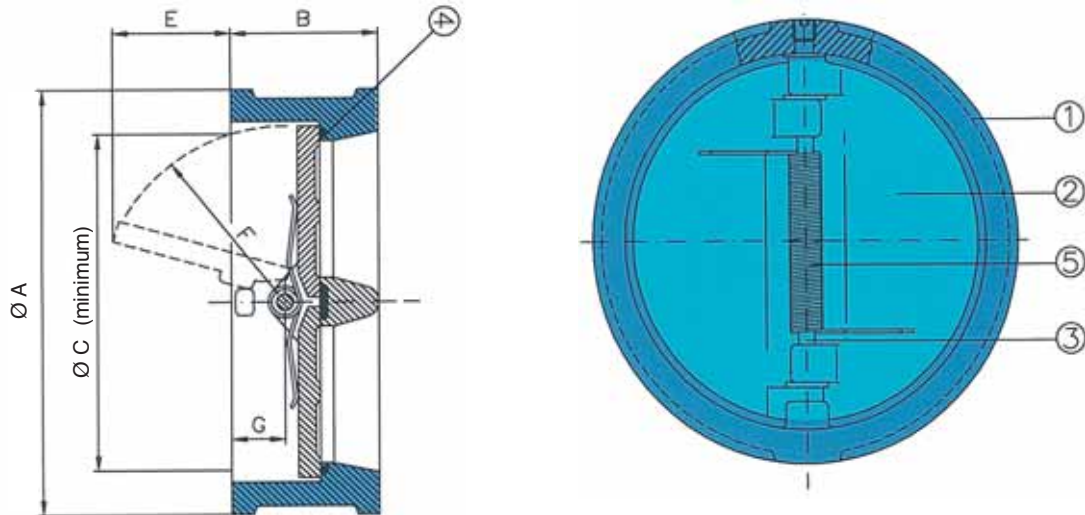

DN	A					B				C				E	F	G	WEIGHT PN 10/16 KG	WEIGHT PN 25 KG
	mm	"	PN 10	PN 16	ANSI 125/150*	PN 25	PN 40	PN 10	PN 16	ANSI 125/150	PN25	PN 10	PN 16					
40	1 1/2	94	-	94	94	43**				55				12	33	21	1	1
50	2	108	104	108	108	43				55				12	33	21	1.3	1.3
65	2 1/2	128	124	128	--	46				58,5				12	33	18,7	2.4	2.4
80	3	143	136	143	143	64				71				18	41	30,8	3.2	3.2
100	4	163	169	169	169	64				96				28	52	30,2	4.2	4.2
125	5	194	194	194	194	70				125				35	70	30,3	7	7
150	6	219	219	224	224	76				128				33	70	37	9	9
200	8	275	275	284	293	89				192				60	104	36	15	15
250	10	329	338	338	355	114				244				81	126	48	27	27
300	12	380	408	402	419	114				295				100	153	49	34	34
350	14	440	450	458		127				320				108	168	57	55	55
400	16	490	514	514		140				380				137	195	58	70	70
450	18	540	556	543		152				420				152	217	65	100	160
500	20	595	618	605		152				480				175	247	65	120	180
600	24	696	735	716		178				585				222	299	77	180	260
700	28	810	810	830		229				690				250	352	103	260	500
800	32	915	915	937		241				780				290	395	107	350	620
900	36	1015	1015	1046		241				850				332	445	112	520	780
1000	40	1124	1124	1216		300				940				332	483	152	760	1200
1200	48	1340	1340	1380		350				1150				442	601	159	1200	2000

*ONLY FOR INSTALLATION BETWEEN FLANGES

**FIGURE NOT ACCORDING TO ISO 5752.

(SEE OUR MODEL B (PAGE 8-9))

Dual Plate Check Valves

Belgicast Model B Ruber-Check

Dual plate check valves
Wafer type

DN 50/1000
PN 10/250 or Class 150/1500



Features:

- Face to face: API 594.
- Wafer check valves with dual plates. Rubber or metal seated.
- Can be used in all type of services and for different types of fluids.
- Allows to install in versatile position.
- Quick and silent closing due to the spring action.
- Temperature from -250°C up to +520°C.
- Anti-corrosive coating against weathering and abrasion and for high service temperatures.
- Easy maintenance.
- Maximum working pressure: 250 bars

Materials:

- Body and plates: carbon steel, alloys, stainless steel, duplex, etc.
- Shafts: AISI-304, AISI-316, Monel 400.
- Springs: AISI-302, AISI-316, INCONEL-X.
- Seats: metal-metal, nitrile, EPDM, viton.
- Other materials upon request.

Function:

The dual plates open due to the pressure of the pump and close automatically when pump is turned off due to the water column and the spring action.

When installing the check valve at pump outlet, take care to make the installation as far as possible from diffusing cone and elbows. Choose an area of stable flow. It is recommended to install the valve after a straight length of pipe 5 times higher its DN.

SIZE	RATING		CLASS 125 CLASS 150 PN-10 PN-16 PN-25	CLASS 300 PN-40	CLASS 600 PN-64 PN-100	CLASS 900 PN-160	CLASS 1500 PN-250
	Ø mm	Ø "					
50	2	2,5	2,5	2,5	3	6	6,5
65	2 1/2	4	4	4	4,5	7	7
80	3	5,5	5,5	5,5	6	12,5	13
100	4	7	7,5	7,5	10	16	18
150	6	15	15	17	38	50	50
200	8	30	30	34	65	85	85
250	10	42	42	50	100	130	140
300	12	74	74	80	140	165	180
350	14	80	80	140	160	360
400	16	120	120	180	260	450
450	18	160	160	250	390	620
500	20	180	180	330	600	780
600	24	260	260	500	920
750	30	500	500	950
800	32	620	620	1000
900	36	780	780	1500
1000	42	1200	1200	2500
1200	48	2000	2000

Approx. Weight(kg)

Dimensions:

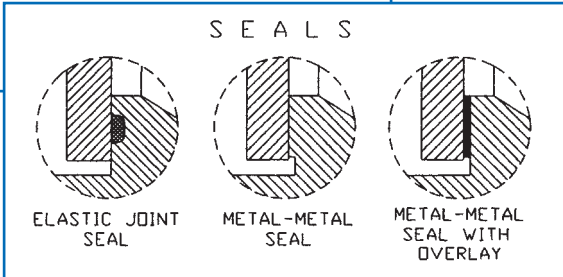
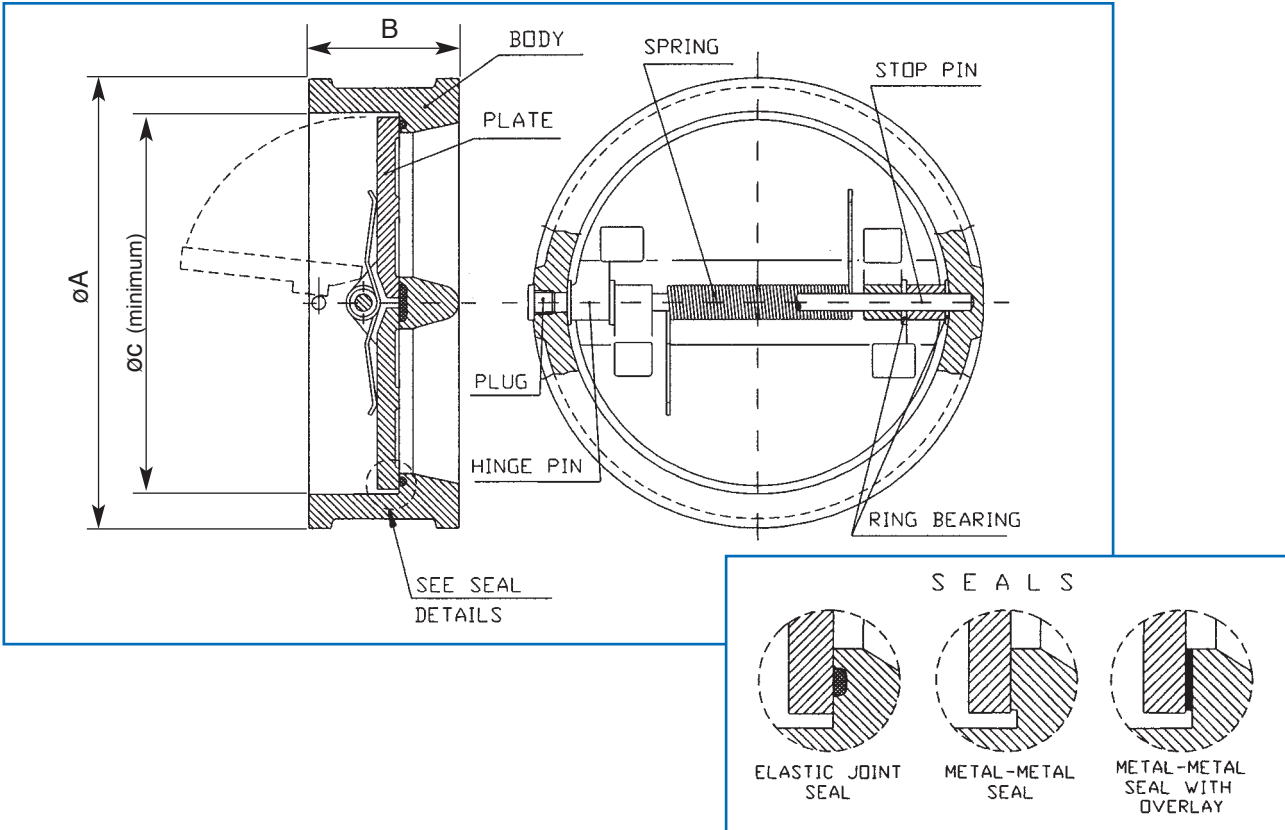

DN		CLASS 150			CLASS 300			PN-10			PN-16			PN-25			PN-40		
mm	"	A	B	C	A	B	C	A	B	C	A	B	C	A	B	C	A	B	C
50	2	104	60	28	108	60	28	108	60	28	108	60	28	108	60	28	108	60	28
65	2 1/2	124	67	-	128	67	-	128	67	-	128	67	-	128	67	-	128	67	-
80	3	136	73	40	143	73	40	143	73	40	143	73	40	143	73	40	143	73	40
100	4	169	73	88	179	73	88	163	73	88	163	73	88	169	73	88	169	73	88
125	5	194	83	110	215	86	110	194	83	110	194	83	110	194	83	110	194	83	110
150	6	219	98	112	248	98	112	219	98	112	219	98	112	224	98	112	224	98	112
200	8	275	127	175	306	127	175	275	127	175	275	127	175	284	127	175	293	127	175
250	10	338	146	210	360	146	210	329	146	210	329	146	210	338	146	210	355	146	210
300	12	408	181	270	419	181	270	380	181	270	380	181	270	402	181	270	419	181	270
350	14	450	184	300	484	222	320	440	184	300	440	184	300	460	184	300	476	222	320
400	16	514	191	372	538	232	370	490	191	372	495	191	372	514	191	372	548	232	370
450	18	548	203	416	595	264	430	540	203	416	556	203	416	565	203	416	572	264	430
500	20	605	219	560	652	292	460	595	219	560	618	219	560	625	219	560	630	292	460
600	24	716	222	580	772	318	550	696	222	580	735	222	580	733	222	580	748	318	550
*700	28	830	282	640	895	370	680	810	282	640	810	282	640	834	282	640	853	370	680
750	30	880	305	662	950	370	720	-	-	-	-	-	-	-	-	-	-	-	-
*800	32	937	305	750	1000	420	770	915	305	750	915	305	750	942	305	750	974	420	770
900	36	1046	368	830	1115	480	880	1015	368	830	1015	368	830	1042	368	830	1084	480	880
1000	40	-	-	-	-	-	-	1124	431	890	1124	431	890	1154	431	890	1194	540	995

*DN700, DN800 NOT ACCORDING TO API-594

DN		CLASS 600			CLASS 900			CLASS 1500			PN-64			PN-100			PN-160			PN-250		
mm	"	A	B	C	A	B	C	A	B	C	A	B	C	A	B	C	A	B	C	A	B	C
50	2	108	60	28	140	70	-	140	70	-	114	60	28	120	60	28	120	70	-	136	70	-
65	2 1/2	128	67	-	162	83	-	162	83	-	138	67	-	146	67	-	144	83	-	154	83	-
80	3	146	73	40	166	83	60	172	83	60	149	73	50	155	73	50	154	83	60	172	83	60
100	4	190	80	88	203	102	80	208	102	80	175	80	88	182	80	88	181	102	80	202	102	80
150	6	265	137	105	286	159	130	280	159	130	248	137	105	258	137	105	258	159	130	285	159	130
200	8	318	165	180	356	206	170	350	206	170	310	165	180	325	165	180	325	206	170	360	206	170
250	10	397	213	230	432	241	210	432	247	210	356	213	230	390	213	230	390	241	210	442	247	210
300	12	455	229	280	496	292	260	518	305	255	425	229	280	460	229	280	458	292	260	540	305	255
350	14	490	273	315	518	356	290	575	356	290	487	273	315	512	273	315	-	-	-	-	-	-
400	16	562	305	360	572	384	320	640	384	320	544	305	360	572	305	360	-	-	-	-	-	-
450	18	610	362	402	636	451	400	702	468	400	588	362	402	628	362	402	-	-	-	-	-	-
500	20	680	368	450	696	451	420	754	533	420	658	368	450	706	368	450	-	-	-	-	-	-
600	24	788	438	540	836	495	540	900	559	540	766	438	540	818	438	540	-	-	-	-	-	-

Check Valve "Ruber-Check"

EMG/Model from DN 40 to DN 300

PN 6/10/16, ANSI 150



Characteristics:

- Centering lugs for mounting between flanges: PN 6, PN 10, PN 16, ANSI 150, BS Table E/D, JIS 5K/10K.
- Internal fully lined body with NBR or EPDM.
- Cassette type internal parts allowing easy replacement (plates, shaft, springs).
- No flange gasket required.
- Face to face distance according to DIN 3203 K3.
- No exterior holes or holes or plugs in the body.

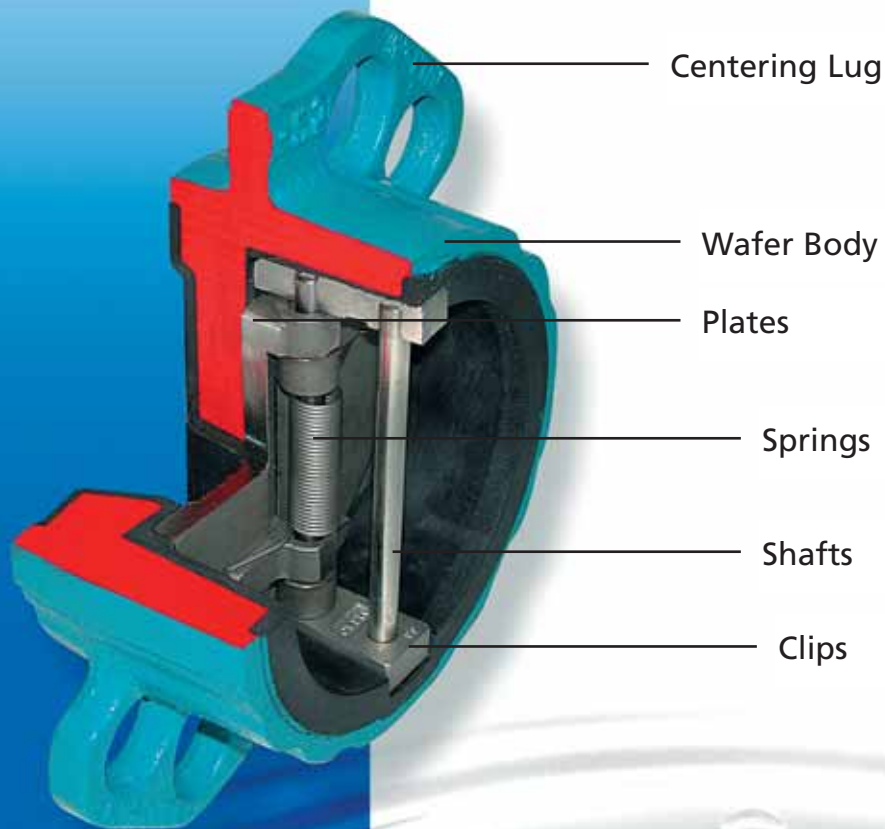

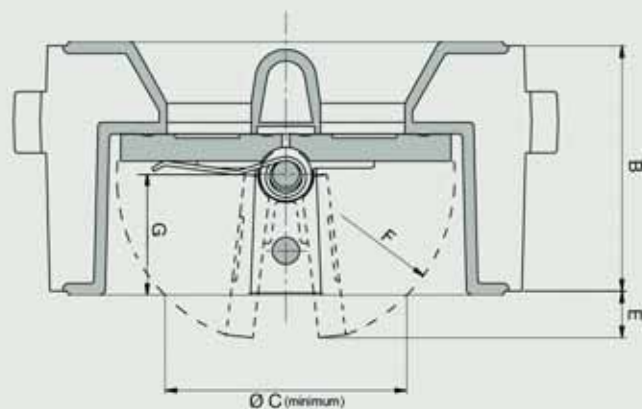
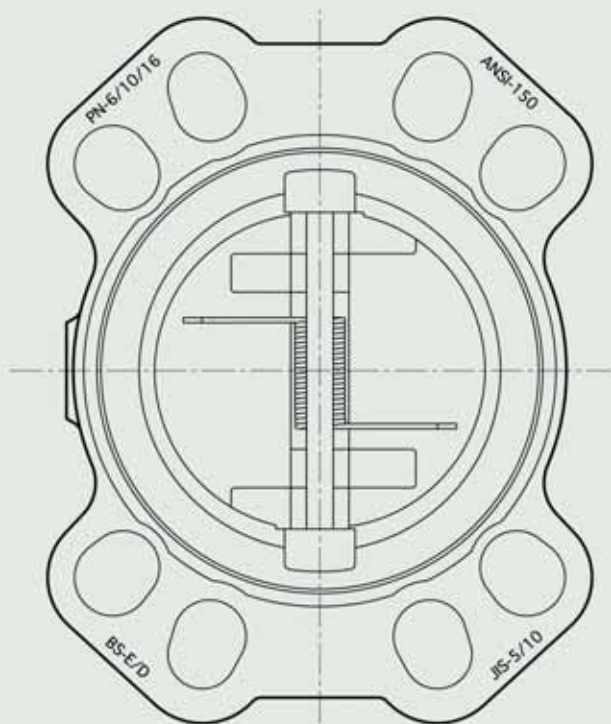

DN		Dimensions in mm.				
mm	inch	B	C	E	F	G
40	1 1/2	33	43	8	23,5	15
50	2	43	49	10	29	21
65	2 1/2	46	64	14	35,5	22
80	3	64	70	11	42	30
100	4	64	91	21	51,5	30
125	5	70	125	38	66	32
150	6	76	148	47	77	32
200	8	89	200	64	101	35
250	10	114	240	78	129	48
300	12	114	300	103	158	50

Internal Code	Body	Plates	Shafts	Springs	Clips	Wedge
105	Grey cast	Stainless steel AISI 316	Stainless steel AISI 304	Stainless steel AISI 302	Stainless steel AISI 316	NBR
701	Grey cast	Stainless steel AISI 316	Stainless steel AISI 304	Stainless steel AISI 302	Stainless steel AISI 316	EPDM
177	Ductile iron	Stainless steel AISI 316	Stainless steel AISI 304	Stainless steel AISI 302	Stainless steel AISI 316	NBR
718	Ductile iron	Stainless steel AISI 316	Stainless steel AISI 304	Stainless steel AISI 302	Stainless steel AISI 316	EPDM

Remarks:

- Internal: 177 y 718. Dimensions: DN 40 to DN 65
 - Internal: 105 y 701. Dimensions: DN 80 to DN 300
- For other type of material for shaft and springs, please request.

Fluid conditions:

- Maximum working pressure: 16 Bar
- Maximum working temperature: NBR = 80°C EPDM = 120°C

Axial Disc Check Valve

Belgicast BV-05-92

Iprocheck

Axial disc check valve
Flanged ends

DN 50/250
PN 10/16



Characteristics:

- Axial disc check valve for protection and non-return on pumping equipment for either clean or/and filter water.
- High hydraulic performance.
- Total sealing (from 3 m.w.c. in vertical position).
- Silent operation.
- May be fitted in horizontal or vertical position.
- Excellent water hammer performance.
- Temperature from -10°C to +80°C.
- Anti-corrosion epoxy protection.
- Easy maintenance

Operation:

When the pumping equipment is in operation, the disc is pushed back allowing the fluid to flow.

When the pump stops, the disc is quickly closed by spring pressure before any over-pressure occurs due to the return flow.

12



Belgicast BV-05-92P

Axial disc foot valve
Flanged ends

DN 50/250
PN 10/16

Characteristics:

- Axial disc foot valve to prevent the priming in suction pumps.
- The strainer basket protects pumping equipment against the entry of foreign objects capable of damaging impellers and other pump components.

Head loss:

BV-05-92

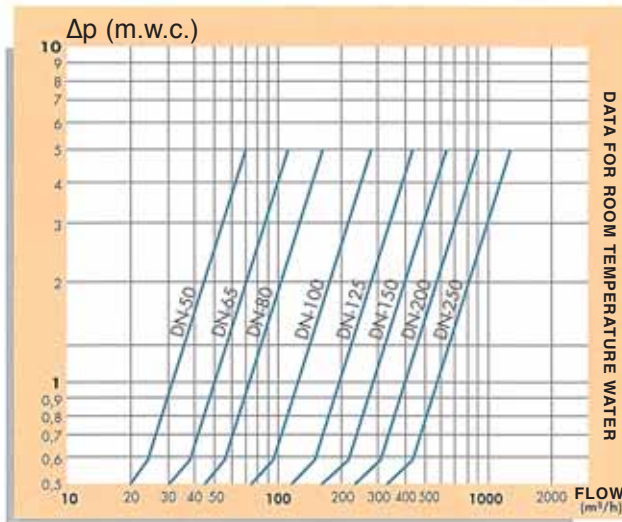

BV-05-92P

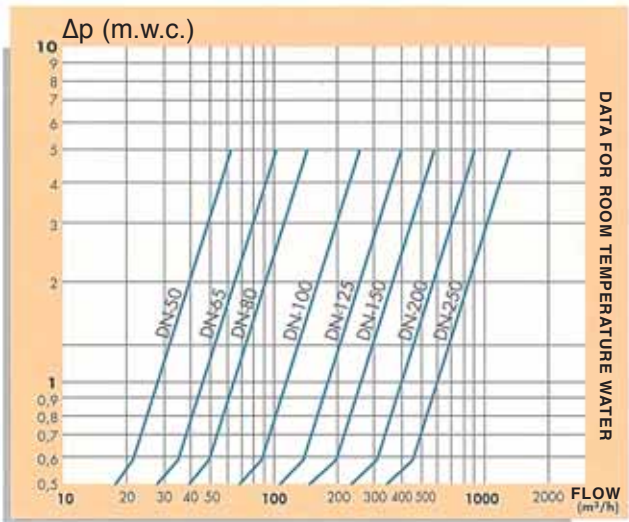

Specifications and dimensions:

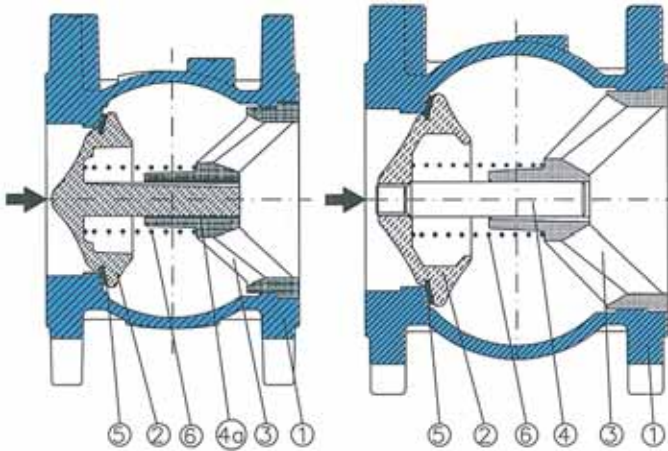

N°	NAME	N° OF PARTS	MATERIAL
1	BODY	1	GG-25
2	WEDGE	1	GG-25
3	GUIDE	1	GG-25
4	STEM	1	AISI 303
4a	BUSH	2	DN 50/80 NYLON 6-52Mo DN 100/150 ST. STEEL AISI 300 DN 200/250 BRONZE
5	SEALING GASKET	2	BUNA-N
6	SPRING	2	AISI 302
7	STRAINER	1	CADMIUM STEEL or AISI 304

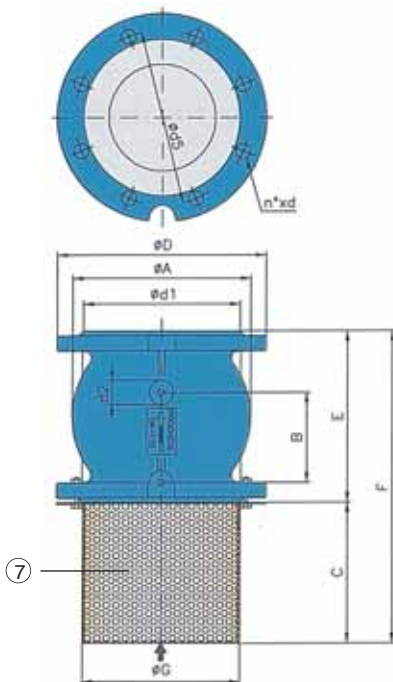

DN	PN-10		PN-16		A	B	C	D	E	F	G	d1	d2	KVo m³/h	Valve Weight Kg.	Basket Weight Kg.
	d5	n°xd	d5	n°xd												
50	125	4x19	125	4x19	96	45	77	165	100	177	91	102	25	100	6.0	0.4
65	145	4x19	145	4x19	121	56	100	185	120	220	127	120	25	160	5.5	0.7
80	160	8x19	160	8x19	140	73	125	200	136	261	127	138	25	230	11.0	0.8
100	180	8x19	180	8x19	185	83	142	220	175	317	164	158	30	390	15.0	1
125	210	8x19	210	8x19	214	97	166	250	200	366	180	188	30	625	23.0	1.5
150	240	8x23	240	8x23	248	114	200	285	234	434	212	212	30	900	30.0	2.7
200	295	8x23	295	12x23	345	-	300	340	300	600	255	270	-	1100	48.5	3.5
250	350	12x23	355	12x27	415	-	380	405	370	750	330	320	-	1800	81.5	4.5

Swing check valve



Belgicast BV-05-37

SWING CHECK VALVE
WITH FLANGED ENDS

DN - 50/400

PN - 10/16

Characteristics:

- Non-return valve with rubber sealing.
- Total watertightness.
- For clean water and sewage.
- Synthetic coating.
- Temperature from -10°C up to +80°C

Specifications and dimensions:

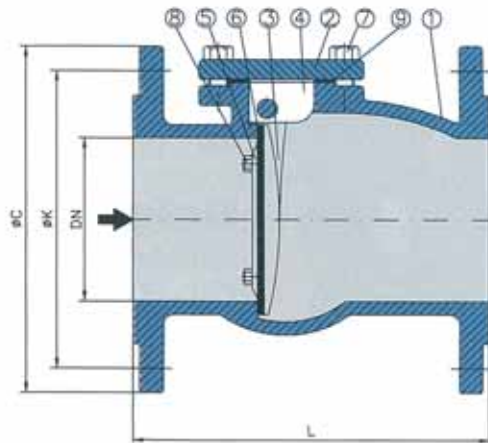
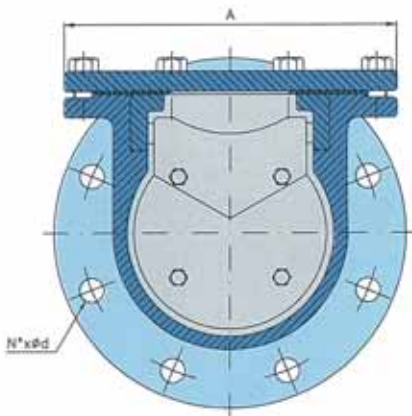

DN	Maximum working pressure Kg/cm ²	Water test pressure Kg/cm ²
50 to 300	16	24
350 to 400	10	15

DN	ØC	ØK	L	A	Nr	Ød	Weight
50	175	125	150	130	4	19	8
65	190	145	178	145	4	19	11
80	200	160	190	165	8	19	13
100	220	180	210	185	8	19	16
125	250	210	275	230	8	19	28
150	285	240	320	275	8	23	41
200	340	295	390	350	12	23	77
250	405	355	480	425	12	28	116
300	460	410	570	485	12	28	174
350	520	470	630	555	16	28	201
400	580	525	720	650	16	31	314

N°	NAME	N° OF PARTS	MATERIAL
1	BODY	1	GG-25
2	COVER	1	GG-25
3	SWING	1	GG-25
4	SPIN COLLAR	2	BRONZE RG. 5 21096
5	SUBJECTION DISC	1	GG-25
6	WEDGE	1	NEOPRENE
7	FASTEN SCREW	-----	STEAL DIN 933/6.8
8	SUBJECTION SCREW	-----	STEAL DIN 931-34/6.8
9	WATERTIGHTNESS JOINT	1	CARTON KLINGER OR SIMILAR



ATEX

POTENTIALLY EXPLOSIVE
ATMOSPHERES DIRECTIVE
94/9/EC



Dimensions, design and technical data are given merely as a guidance, and can be modified without prior notice according to technical progress.

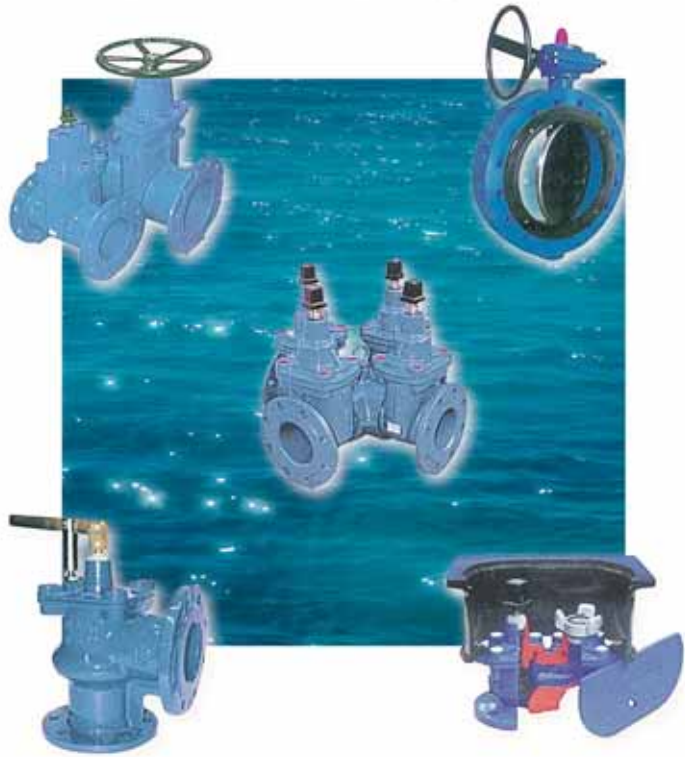

RANGE OF PRODUCTS

SOFT SEALING GATE VALVE
BUTTERFLY VALVE
CHECK VALVE
BALL CHECK VALVE
UNIVERSAL FLANGED ADAPTORS AND
COUPLINGS
SADDLES

tyco / *Flow Control* / **Tyco Waterworks**

Belgicast®



B° Zabalondo, 31 ☒ Apdo. Correos 93
48100 MUNGUÍA (VIZCAYA) - SPAIN
☎ Nacional 944 889 100 - Fax 944 889 130
☎ Internacional +34944 889 120 - Fax +34 944 889 125
E-mail: belgicast@tyco-valves.com
